

LEGEND[®]

INSTALLATION MANUAL



Because reliability matters most

www.pentairpool.com

LEGEND®

LL105G

Important Information:

The Legend® automatic pool cleaner comes ready to connect into a female threaded 1-1/2" line, dedicated to our Universal Booster Pump. Also, if you have a chlorinator, solar system or other air inducing equipment, please contact our Technical Support Department before you install the Legend®. (See diagram on page 2).

The following are important facts to remember before installing and operating the Legend®.

1. Always disconnect the Legend® from the pool wall when cleaning or back washing the pool filter.
2. After cleaning or back washing, let the filtration system run for at least five minutes before reconnecting the Legend®.
3. New plumbing lines should be flushed out before installing the Legend®.
4. The Legend® should not be used to remove plaster dust in new pools.
5. Always remove the Legend® before swimmers enter the pool.
6. Always handle the Legend® with care. Do not let children or pets play with the unit: it is not a toy.
7. Always pick up the Legend® by the Vacuum Tube especially when lifting the unit out of the water.
8. Unless checking the wheel RPM, do not handle the Legend® while it is operating.
9. Always remove the Legend® from the pool before chemical shock treatments. As a rule, any pool water that is unsafe for swimming is unsafe for the Legend®.
10. Carefully cut the feed hose following the instructions on Page 3.

By following these simple guidelines, you can help protect against injury and prolong the life of your Legend®.

Before the Legend® is installed, please take a moment to record the serial number. This number is located on your warranty card and on the back of the Legend® near the rear jet. You will be asked for this number when you contact our Technical Support Department.

SERIAL # _____

TABLE OF CONTENTS

I.	Introduction.....	1
A.	Thank You for Choosing the Legend®.....	1
B.	What to Expect from the Legend®.....	1
II.	Installation Instructions.....	2
A.	Legend® Components.....	2
B.	Pool Connections.....	2
C.	Booster Pump Installation.....	2
D.	Installing the Twist Lock Pressure Relief Valve (Wall Fitting).....	3
E.	Cutting the Feed Hose.....	3-5
F.	Checking Operation.....	6
G.	Fine Tuning the Legend®.....	6
1.	Thrust Jet Adjustment.....	6
2.	Sweep Hose Adjustment.....	6
3.	Checking Wheel RPM.....	6-7
III.	Operation & Periodic Maintenance.....	8
A.	Connecting/Disconnecting the Legend®.....	8
B.	Turning the Legend® On/Off.....	8
C.	Cleaning the Sand & Silt Bag.....	8
D.	Periodic Maintenance.....	8
1.	Wall Fitting Screen.....	8
2.	Tires & Bearings.....	9
3.	Roller Rings.....	9
4.	Debris Bags.....	9
5.	Sweep Hose.....	9
6.	Debris Valve.....	9
E.	Back washing the Pool Filter.....	9
F.	Storage and Winterizing.....	9
G.	Accessories.....	9-10
1.	Sweep Hose Weight.....	9
2.	Leaf Bag.....	10
3.	Step Adapter.....	10
4.	Suction Cup Tires.....	10
IV.	Troubleshooting.....	11-12
	Legend® Parts List.....	13-14
	Legend® Exploded View.....	15

I. Introduction

A. Thank You for Choosing the Legend® Pool Cleaner

Congratulations on the purchase of your new automatic pool cleaner. The Legend® is designed to give you years of dependable and efficient service. With the Legend®, you and your family will spend more time relaxing and enjoying your pool and less time cleaning it.

The Legend® has been designed and built with time proven features and patented innovations to create an automatic pool cleaner that will give you years of dependable service. The Legend® is built with pride in the U.S.A., by people who care about the product using state of the art materials and backed by a limited warranty that protects against defects in parts and construction.

Like any mechanical device, the Legend® requires some preventative maintenance and the replacement of certain hard working parts. We recommend that you have your Legend® checked annually. For best results have your Legend® installed by a qualified swimming pool professional.

For pool owners with plumbing and mechanical experience, installation instructions are included in this manual.

Please put safety first! Be sure to take your Legend® out of your pool and store it carefully in a shaded area before anyone enters the pool.

B. What to Expect from the Legend®

When operating correctly, the Legend® will travel randomly throughout the pool, vacuuming and sweeping the bottom. The climbing ability of the Legend® is dependent on the pools shape. It will climb better in pools without sharp angles or curves in the transition from the pool floor to the pool wall.

The Legend® comes equipped with a Wall Fitting (Part #EW22) that features a Twist Lock Automatic Pressure Relief Valve. If the Legend® is receiving too much water pressure to the unit, the relief valve will automatically reduce water pressure.

Approximately every three minutes and 30 seconds the Legend® will go into a back up mode. At this time the Back-Up Valve will pull the Legend® away from problem areas.

Occasionally some vinyl pools have steps installed so the unit may not climb and remains stationary until the Back-Up Valve pulls the unit away from the steps. When this occurs you need to use the optional Step Adapter (Part#EU13) to prevent wearing the vinyl liner.

The Sweep Hose operates in a gentle sweeping motion to prevent debris from becoming trapped in hard to reach corners of the pool.

II. Installation Instructions

A. Legend® Components

The Legend® Box Contains:

1. Cleaner Head
2. Sand & Silt Bag
3. Sweep Hose
4. Complete Feed Hose
 - a. 1 - 8.5" hose
 - b. 2 - 11'-2" white hoses
 - c. 1 - 20" clear hose/1 - 6' clear hose
 - d. 10 - Floats
 - e. 3 - Swivels
 - f. 1 - Back-Up Valve
 - g. 10 - Mender Nuts
 - h. 1 - Wall Fitting Complete

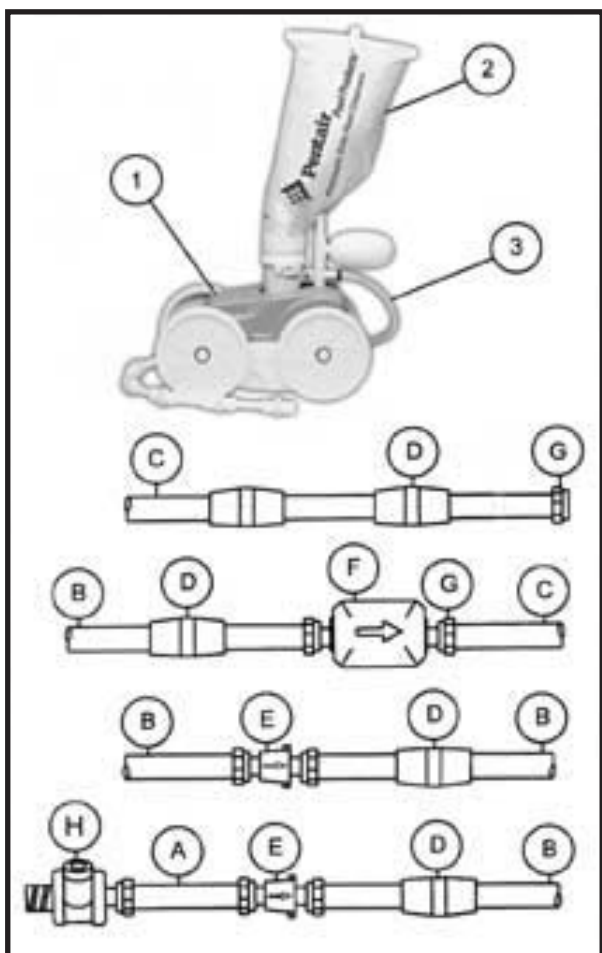

B. Pool Connections

The Legend® comes equipped to connect to a female threaded 1-1/2" line, dedicated to our Universal Booster Pump.

Also, if the pool doesn't have a dedicated cleaner line please contact our Technical Support Department at 1-800-831-7133

C. Booster Pump Installation

If you already have a 3/4 horsepower booster pump installed at your equipment pad and it is operational, skip this section and proceed to Installing the Twist Lock Pressure Relief Valve (Wall Fitting).

Detailed booster pump installation instructions are packaged separately in our booster pump box. **Please follow these instructions carefully.**

The booster pump is not self-priming and needs to be fed with water taken from the pool filter before any type of in-line chlorinator. See figure below.

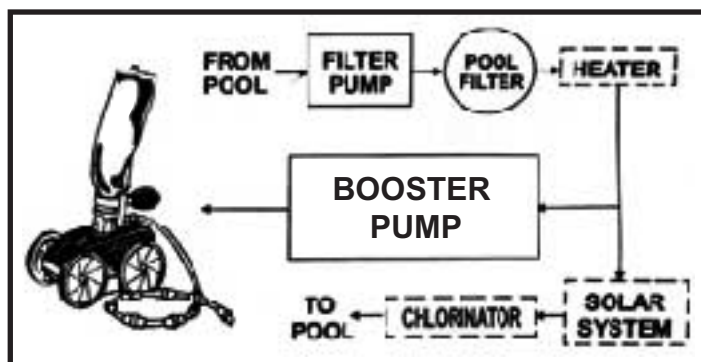

D. Installing the Twist Lock Pressure Relief Valve (Wall Fitting)

1. Take out any existing pool cleaner and/or wall fitting.
2. Turn on the filtration pump and booster pump, flush out the plumbing line.
3. Turn off filter pump and booster pump.
4. Remove the Wall Adapter from the Wall Fitting and screw Adapter by hand into the dedicated line. Turn until tight.

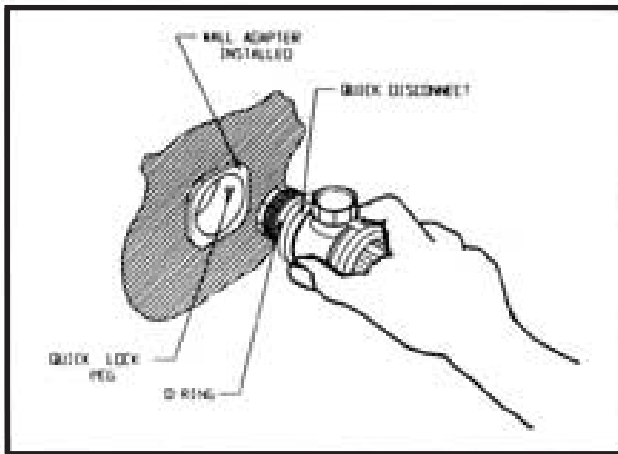

5. Take the Wall Fitting and Twist Lock the Wall Fitting into the Wall Adapter 1/4 turn; to a snug fit. Once the Wall Adapter is secure you can now twist lock and unlock to remove Wall Fitting with ease from the Wall Adapter.

E. Cutting the Feed Hose

The Hose assembly comes in 5 sections now covering approximately 30 ft. of the pool, which provides ample hose for most residential pools. The Back-Up Valve is now 20" from the head cleaner and should always remain this distance. For larger pools see paragraph 12 for instructions on *Adding Additional Feeder Hose*.

1. Take Feeder Hose out of box and lay the hose straight in the sun for one day if possible, (this will take any memory out of the hose due to being coiled up in the box).

2. Attach feed hose to the wall fitting and attach wall fitting to the pool wall. Hold the end of clear hose and walk the perimeter of the pool keeping the hose straight (do not stretch hose) to find the farthest point of the pool from the wall fitting.
3. Measure the excess length between the farthest point of the pool from Wall Fitting and the end of 20 inch clear hose.
4. Half of this measured length is to be **cut equally from 11ft-2inch white hoses next to the Marked Swivel**. (Example: Half of 6ft = 3ft each). If you are cutting more than 2ft off the hoses, remove the floats next to the Marked Swivel from both hoses. See figure next page.
5. Re-assemble the hoses and the swivel using mender nuts. (See the Figure below). Put mender nut on swivels first, then push hose over swivel, rotate mender nut over hose clockwise until tight. *Note: Keep as many floats as possible on white feed hoses spaced evenly apart to hold hose up on top of water.*

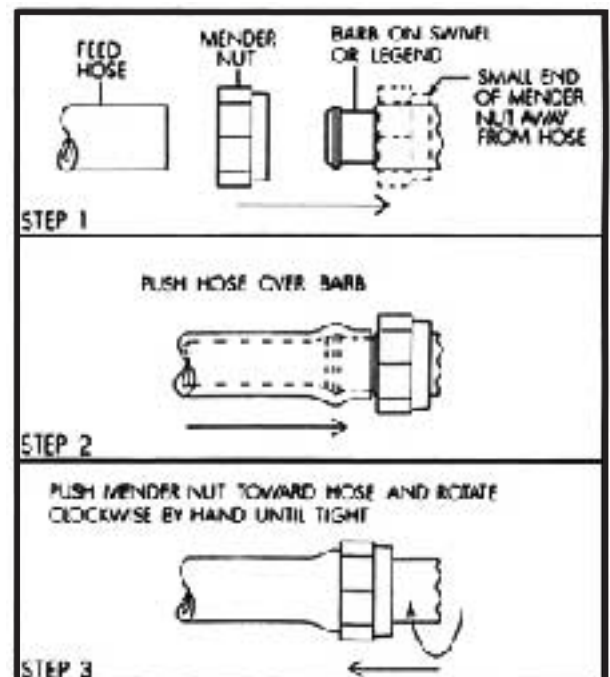

E. Cutting the Feed Hose - (cont.)

6. When cutting hoses, please use strong scissors or a sharp knife. Be sure to slide the floats out of the way when cutting hose.
7. Put extra mender nut on the Legend® mast and push clear hose gently over mast at 1/2", turn mender nut around clear hose tight. Note: The Back-Up Valve still should be 20" from the head of the cleaner.

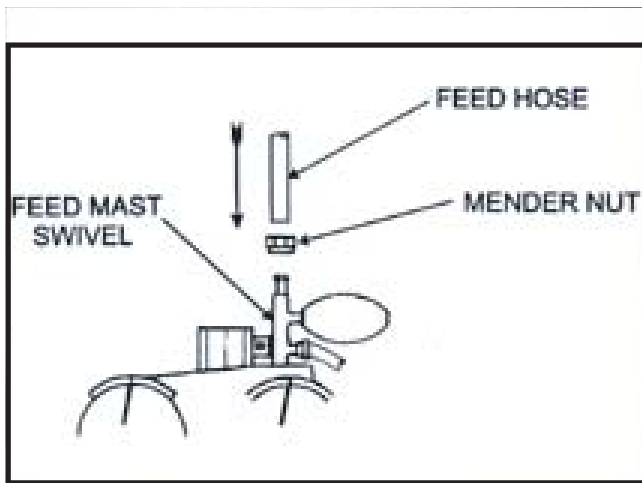

8. Now take the bag, EU16, out of the box and firmly twist lock bag onto the top of Legend® throat over rubber debris valve.
9. Review and check list: White and clear hoses cut properly and floats evenly spaced. Mender nuts tight around swivels, Back-Up Valve, Legend® mast and wall fitting. Make sure wall fitting is securely locked into place.

10. Lower your complete Legend® assembly into your pool carefully. It should look like figure below.

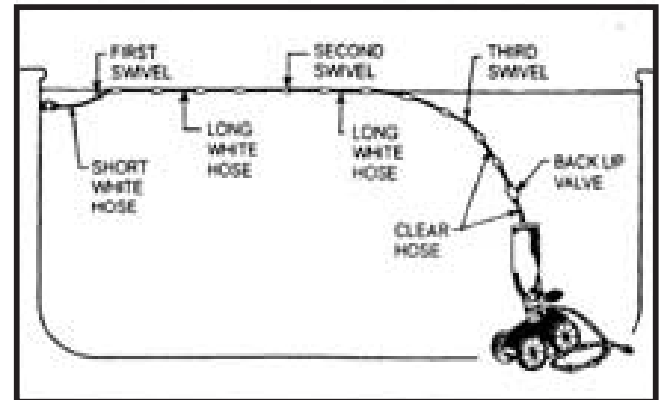

11. Go back to your equipment and turn filter pump on first (wait 30 seconds to force air out of the hose), then turn booster pump on.
12. For adding additional feeder hose for large pools requiring more hose length you will need to purchase one (1) additional hose (ED45), four (4) floats (ED10P), one (1) swivel (ED05), and two (2) mender nuts (ED15). Attach extra white hose between clear hose and existing white hose, using floats, swivel and mender nuts. Divide extra white hose overage by three (3) this time to keep all white the same length.

F. Checking Operation

When operating correctly, the Legend® will travel in a random pattern throughout the pool, vacuuming and sweeping the bottom. The climbing ability of the Legend® is dependent on the pools structure and water flow coming into the pool. It will perform more efficiently in pools without sharp angles or curves in the transition from the floor of the pool to the wall.

The Legend® comes with a Twist Lock Pressure Relief Valve (Wall Fitting). If the Legend® is receiving too much water pressure, the Relief Valve in the Wall Fitting will release the excess water pressure.

Approximately every three minutes and 30 seconds the Legend® will go into a back-up mode. The Back-Up Valve cycle time, while in the back-up mode, is approximately 30 seconds, pulling the Legend® from problem areas.

New Back-Up Valve Information:

The Back-Up Valve Insert (#MBUVP) which is slid into the slot over the jet of the valve. This is secured with a stainless steel screw (#VX-9) as show in the diagram. The insert will be set from the factory with the larger (3/8") hole over the opening of the jet. The larger hole is used for the Legend cleaner. If you change the insert to the smaller (1/4") hole, the Back-Up Valve will have increased jet pressure and possibly tangle your hose.

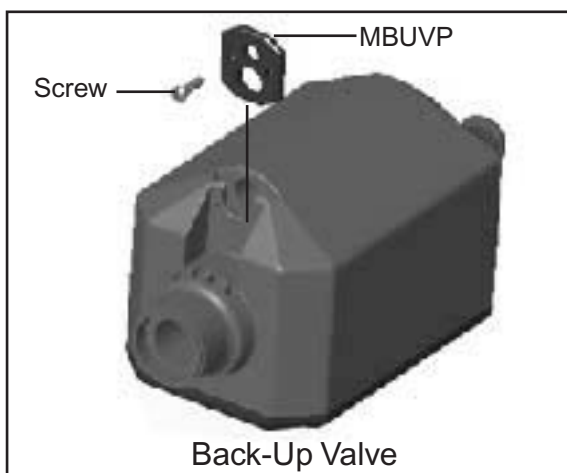

The Sweep Hose operates in a gentle sweeping motion to prevent debris from becoming trapped in hard to reach corners of the pools.

If the Legend® does not travel to all areas of the pool, turn off the booster pump and pool filtration pump and make the necessary adjustments from the instructions in the next section.

G. Fine Tuning the Legend®

1. Thrust Jet Adjustment

There is a Thrust Jet located in the back of the Legend®. This Thrust Jet alters the direction of the cleaner. The factory standard position for the jet is set in the middle and straight out. (See illustration below).

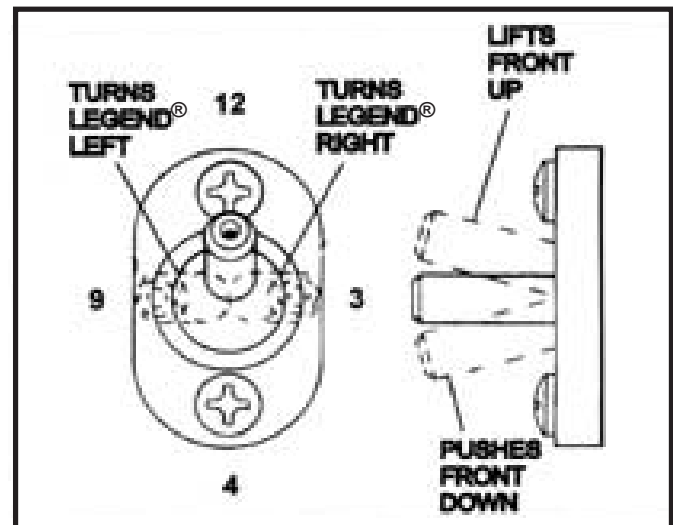

2. Sweep Hose Adjustment

The Sweep Hose operates in a gentle sweeping motion. To increase or decrease the motion of the Sweep Hose, there is an adjustment screw located on the Feed Mast Barb below the

3. Checking Wheel RPM - (cont.)

Mark the front drive Tire/Wheel with a marker, or use the Pentair logo located on the side of tire as a marker to count the rotations of the wheel per minute.

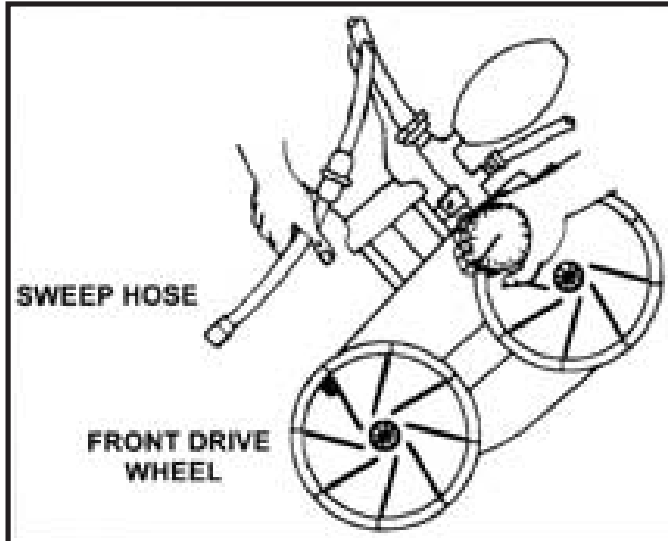

Have someone turn on pool pump and then booster pump while you place the Legend® in the pool just beneath the water surface. (Be sure to hold onto the Sweep Hose to avoid getting wet).

Count the rotations of the marked wheel for exactly one minute. (Be sure the Back-Up Valve isn't cycling at this time). The rotations will give you the Revolutions Per Minute. (RPM)

For proper performance, the Legend® operates between 28-32 RPM. If the RPM is below 28 then call your local Pool Professional or contact our Technical Support Department at 1-800-831-7133.

If the RPM is more than 32, at the Wall Fitting unscrew the Pressure Relief Valve slowly until the RPM falls between 25-32.



If you have any additional questions, please contact Pentair Pool Products Technical Support Department at 1-800-831-7133, Monday through Friday.

III. Operation/Periodic Maintenance

A. Connecting/Disconnecting the Legend®

Turn off booster pump and pool pump. Then take the Wall Fitting and twist lock the Wall Fitting clockwise into the Wall Adapter. To disconnect the Legend®, unlock and twist counter clockwise. The Wall Adapter should remain in the pool wall.

B. Turning On/Off the Legend®

The Legend® operates off the booster pump coming from the equipment pad, and can be turned on or off by merely turning on/off your booster pump time clock.

C. Cleaning the Sand & Silt Bag

Carefully unlock the debris bag from the vacuum tube and open the Velcro® Brand Fastener closure at the top of debris bag and dump debris.

If you have a lot of debris in your pool, especially after a storm, you can run your Legend® in two shorter cycles per day and empty the debris bag between cycles.

Reconnect the debris bag to the vacuum tube. Do NOT over turn.

If the Velcro® Brand Fastener strip on top of the debris bag does not stay secure, rinse well, let it dry and clean with a stiff brush.

A Helpful Hint: It is easier to empty the debris bag when it is dry. A second bag may be used while the full debris bag is drying.

It's best to empty the debris bag when it becomes half full. The Legend® will have better performance if the bag is not overloaded.

D. Periodic Maintenance

The following parts are wear items that should be checked, maintained or replaced as needed. Wear items are considered any working or moving part(s) being worn due to the use of the cleaner. ***Wear items are not covered under warranty.***

1. Wall Fitting Screen

Inside the wall fitting is a filter screen that acts as a secondary filter. This screen is to keep debris that is passed by the pool filter out of the Legend®. *Running the Cleaner without the filter screen can damage the Legend® and will void the warranty.*

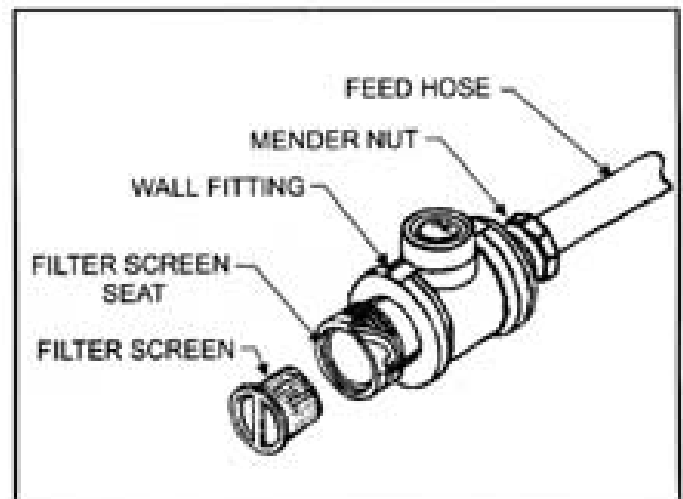

A continuous plugged or dirty screen is a sign of problems in your pool filtration system and you need to contact your local pool professional.

To clean the filter screen, pull the screen out from inside the Wall Fitting and rinse thoroughly and push back inside the wall fitting.

Whenever cleaning, back washing or repairing filter, remove the wall fitting and flush out the dedicated line before using the Legend®.

III. Operation/Periodic Maintenance - (cont.)

2. Tires & Bearings

The tires are designed to protect the bottom of your pool and provide better traction. You need to rotate or replace the tires when edges become rounded.

The Wheel Bearings are warranted free of defects when shipped and are considered a wear item. A good bearing will spin freely.

3. Roller Rings

Your Sweep Hose has a series of Roller Rings to protect the Sweep Hose. Replace the rings as needed. You can rotate the Roller Rings to prevent flat spots.

4. Debris Bags

Fine Mesh Sand & Silt Bag

The Legend® comes with a Sand & Silt bag for general use in all pools. We do not recommend using the fine mesh bag to pick up leaves and twigs or other large debris for they have sharp points and edges that can poke holes and eventually rip the bag.

Optional Leaf Bag

The leaf bag is a larger mesh bag made to pick up heavier debris such as leaves, twigs, acorns, etc. This bag can be helpful especially after a storm.

A Helpful Hint: To prolong the life of bags, remove cleaner from pool before adding chemicals.

5. Sweep Hose

The Sweep Hose is provided to help keep the bottom and sides of your pool clean. The Sweep Hose is warranted free of defects when shipped from the factory, and is considered a wear item.

6. Debris Valve

This valve is located under the Debris Bag, it is designed to keep the debris inside the bag. It functions like a check valve to allow the debris to only enter through the bag one way. Replacement is needed when valve begins to stiffen.

E. Back Washing the Pool Filter

Always disconnect the Legend® from the pool wall before cleaning or back washing the pool filter. After cleaning or back washing, let the pool filtration system run for a minimum of five minutes to flush out the return lines before reconnecting the Legend®.

F. Storage and Winterizing

Never leave or store the Legend® in direct sunlight. When storing the Legend® for the winter, be sure to drain all the water from it. This is important since freeze damage is not covered under the warranty. Also, remove the Wall Fitting.

G. Accessories

1. Sweep Hose Weight

If the sweep hose tends to break the surface of the water therefore squirting nearby windows or innocent bystanders, a weight can be installed to the end of the sweep hose.

(Part # for Hose Weight is EH09C)

III. Accessories (cont.)

2. Leaf Bag

(See previous page)

3. Step Adapter

This adapter is designed for vinyl liner pools that have steps installed in such a way that the unit may not climb and remains stationary until the Back-Up Valve comes on. The adapter acts as a bumper to turn the cleaner away from the steps and continue on cleaning your pool.

It's easy to install: Simply slide the Step Adapter into one of the slots (either side) located in the front of your Legend® and adjust to the appropriate height.

(Part # for Step Adapter is EU13)

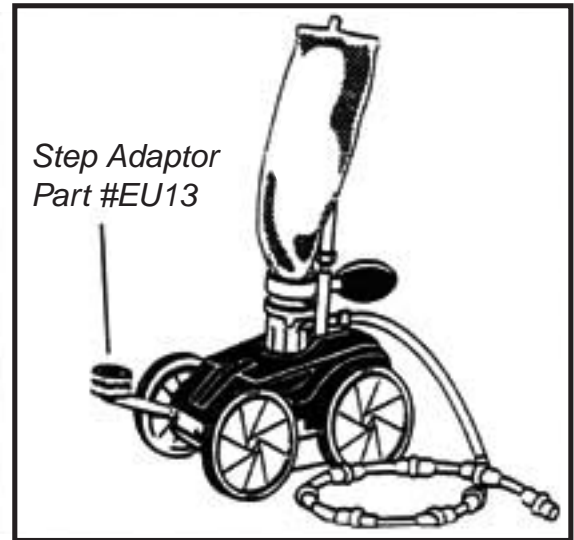

4. New Legend Suction Cup Tires

Designed to climb in problem areas, fiberglass, tile and smooth surfaces. For other applications, please contact our Technical Service Department.

(Part # for Suction Cup Tires is LC6LSA)



IV. TROUBLESHOOTING AND PERFORMANCE TIPS

To insure the best performance from your cleaner, follow the troubleshooting guide listed below.

A. PROBLEMS & SOLUTIONS

Problem: Legend® doesn't move or moves sluggishly or hangs up on steps.

Solution:

1. Be sure filter pump and booster pump are on and working properly. (You may need to clean your pool filter system).
2. Check the Wall Fitting screen for debris and rinse clean.
3. Check wheel RPM (See page 6-7).
4. Determine if the Back-Up Valve is cycling. (Hold the valve out of the water and the jet should come on for approx. 30 seconds and shut off for approx. 3 minutes and 30 seconds).
5. Check all the Hose connections and Swivels for leaks that can cause loss of water pressure.
6. Check debris that may be jammed in the gear teeth on one of the front drive wheels. Gently rotate the front wheels backward to dislodge debris.

Problem: Legend® falling over or lying on its side.

Solution:

1. This usually indicates the bag needs to be emptied.
2. Check to see if the ballast float (EA20) is leaking by checking if there is water inside. Unscrew by pulling back while turning counter-clockwise. When it comes off, shake it and listen for water in float.

Problem: Legend® will not back up.

Solution:

1. Determine if the Back-Up Valve is cycling. (Hold the valve out of the water and the jet should come on for approx. 30 seconds, and shut off for approx. 3 minutes and 30 seconds).
2. Check the wheel RPM (See page 6-7).
3. Empty the debris bag if full or half full.

Problem: Legend® will not climb.

Solution:

1. Even if your pool doesn't show algae you still need to brush the sides of the pool wall.
2. Check the wheel RPM (See page 6-7).
3. Reposition the Thrust Jet. Loosen the two screws to adjust the Thrust Jet. Instructions for different positioning are located on page 10.

A reminder: The climbing ability of the Legend® is dependent on the pool's shape and available water pressure. It will climb better in pools without sharp angles or curves in the transition from the pool floor to the pool wall.

Problem: Hoses tangling.

Solution:

1. Check the length of the Feed Hose, they may be too long. (See pages 3 through 5).
2. Check to see that the Feed Hose is floating on top of surface. Check hose floats for even spacing.
3. Twist the Hose Swivels to see if they spin freely and replace any that will not.
4. Lay out the Feed Hose straight in the full sun to remove any memory.

IV. TROUBLESHOOTING AND PERFORMANCE TIPS

A. PROBLEMS & SOLUTIONS - (cont)

Problem: Sweep Hose is sucked into the cleaner.

Solution: **1.** Adjust the Sweep Hose using the Adjustment Screw located on the bottom of the Swivel Mast and just below the upper Thrust Jet. Turn Adjustment Screw clockwise until the Sweep Hose is in a gentle sweeping motion.

Problem: Sweep Hose breaks water surface and sprays nearby windows, patio decks and bystanders.

Solution: **1.** Adjust Sweep Hose to a gentle sweeping motion.
3. Add optional Sweep Hose weight (See Page 9).

Problem: Booster Pump very noisy.

Solution: **1.** Make sure Wall fitting is mounted in pool wall correctly.
2. Make sure Pool Filtration system is working properly.
3. Contact your local Pool Professional -possible Booster Pump problem.

LEGEND® PARTS LIST

<i>Part #</i>	<i>Diagram #</i>	<i>Description</i>	<i>Quantity</i>
LLU5N	1	Top Cover	1
LLU145N	2	Main Frame	1
EU10N	3	Bottom Cover	1
LLU6	4	Feed Mast w/O-Ring	1
EC86	5	Turbine Drive Shaft - Complete	1
EC83	6	Turbine Spacers	2
EC80	7	Turbine Bearings	2
EA40	8	Turbine Shaft Shield	1
EC110	9	Turbine Cover w/Elbows	1
EX120	10	Turbine Cover Hose - 9" length	1
EC120	11	Venturi Jet - Hose - 7 3/4" length	1
EB5L	12	Sweep Hose - Complete	1
EB10	13	Sweep Hose - Wear Ring	9
EB25	14	Sweep Hose - Jet w/Collar	1
EB20	15	Sweep Hose - Adjustment Screw	1
EA20	17	Ballast Float	1
EH07	18	Sweep Hose - Hose Sleeve	17
EU15	19	Coarse Mesh Bag (Optional)	1
EU16	20	Fine Mesh Bag	1
EU9	21	Debris Valve	1
EU7	22	O-Ring for Feed Mast	1
E18	23	O-Ring for Thrust Jet	1
EC130	24	Thrust Jet	1
EC135	25	Thrust Jet - Plate	1
EC65	27	Axle - Large Wheels	4
EC70	28	Axle Plate	4
EC45	34	Axle - Lock Washer	8
EC6L	36	Wheel w/out Bearings	4
EC60	37	Wheel Bearings Only	8
E10	38	Back-Up Valve	1
EC55	39	Wheel Screw - Plastic	4
LLC1	40	Wheel - Rubber Tire	4
EB15	41	Hose Clamp	5
EC40	42	Screw	8

LEGEND® PARTS LIST

Part #	Diagram #	Description	Quantity
ED50	44	Feed Hose - clear soft - 7'-8"	1
ED10P	45	Float - Feed Hose	10
ED45	46	Feed Hose - white - 11'-2"	2
ED05	47	Swivel - Feed Hose	2
LLU1	48	Adapter Hose - white - 8-1/2"	1
ED15	49	Mender Nut - plastic - feed hose	8
EW22	50	Wall Fitting	1
E24	51	Screen - Wall Fitting	1
E23	52	Quick Disconnect Adapter	1
EC64	53	Wheel - Plastic Washer	4
EH09C	54	Sweep Hose Weight	1
EG16	55	Gears - for Back-Up Valve	1
EC131	56	Thrust Jet Repair Kit includes: LLC130, LLC153, LLC140	1
EA30	57	Screw for LLA40 and LLC110	5
EU76	60	Axle Bolt	8
EU147	62	Snap Fit Vac Tube Posts	2
EU79	63	Nut & Bolt - Feed Mast to Vac Tube	1
LLU8	64	Venturi Jet	2
EU80	65	Hex Screw - Cover to Frame	2

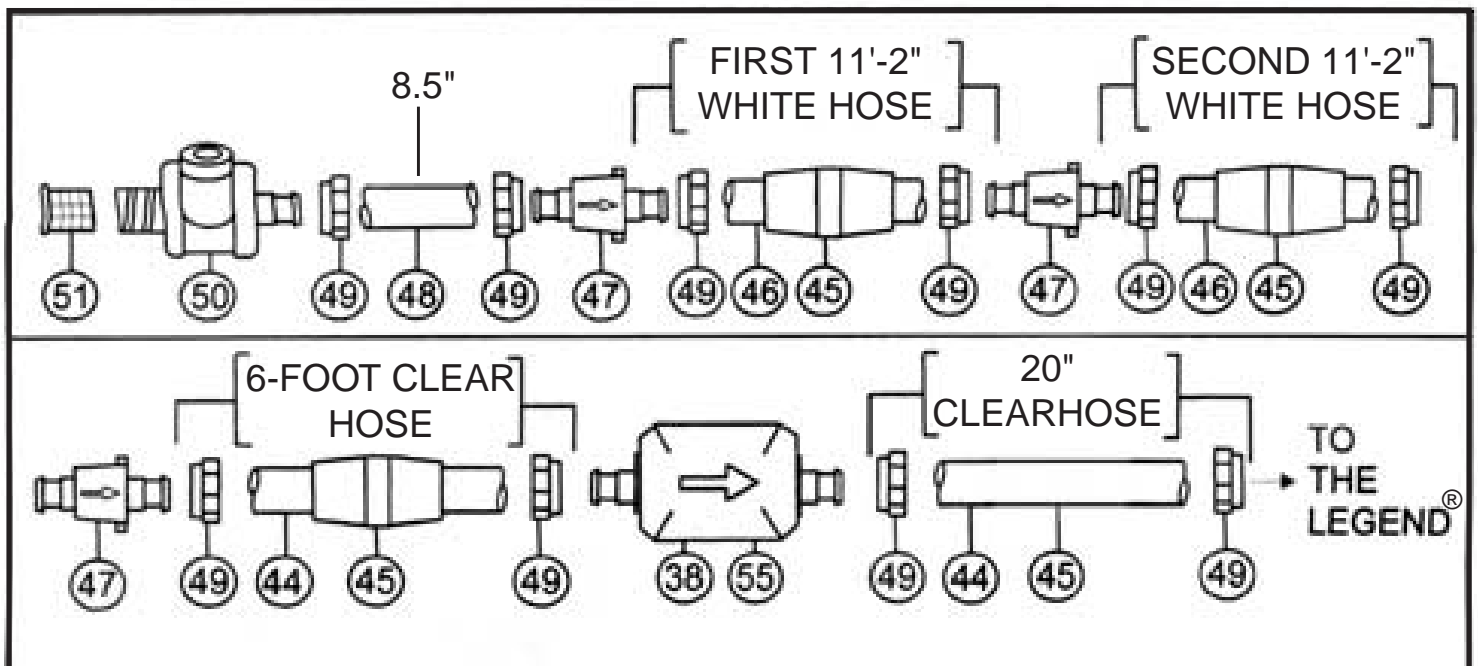

LEGEND® EXPLODED VIEW

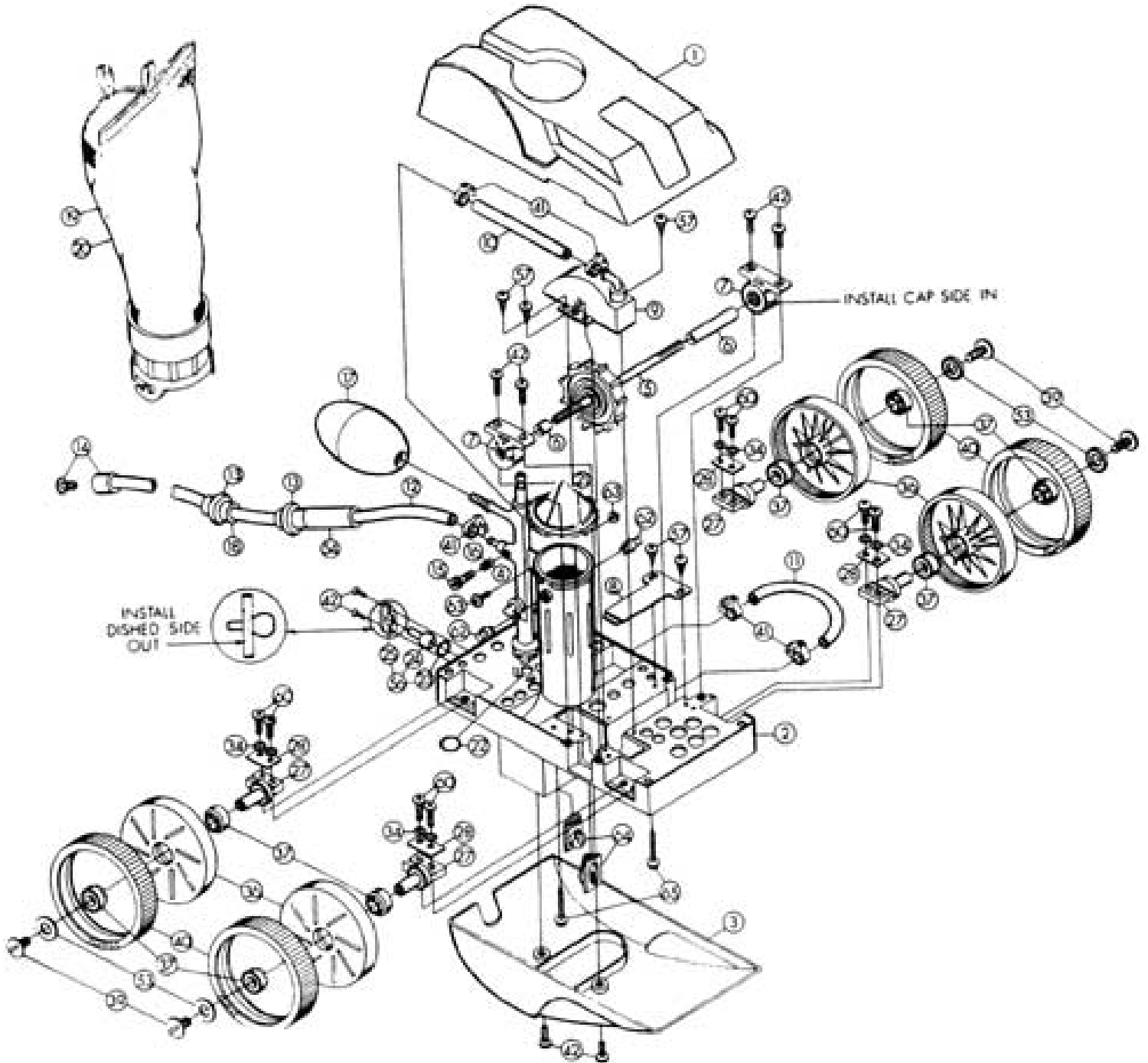



*Because **reliability** matters most*

Pentair Pool Products, Inc.

800-831-7133